

SLR-24H PHOTOELECTRIC/ HEAT SMOKE DETECTOR



Shown without base.

STANDARD FEATURES

- Low profile, 2.2" high (with base)
- 2 or 4 wire base compatibility, relay bases available
- 135°F latching heat sensor
- Heat sensor protected by a built-in guard
- Highly stable operation, RF/Transient protection
- Low standby current - 45 μ A at 24VDC
- Two built-in power/sensitivity supervision/alarm LEDs
- Non-directional smoke chamber
- Vandal resistant security locking feature
- Removable smoke labyrinth for cleaning or replacement
- Automatic Sensitivity window verification function meets outlined requirements in NFPA 72, Chapter 2& 7, Inspection, Testing and Maintenance.

SPECIFICATIONS

Light Source	GaAlAs Infrared Emitting Diode
Heat Sensor	135°F
Rated Voltage	17.7 - 30.0 VDC
Working Voltage	15.0 - 33.0 VDC
Maximum Voltage	42 VDC
Supervisory Current	45 μ A @ 24 VDC
Surge Current	160 μ A max. @ 24 VDC
Alarm Current	150mA max. @ 24 VDC
Ambient Temperature	32°F to 120°(0°C to 50°C)
Maximum Humidity	98% RH Non-Condensing
Color & Case Material	Bone PC/ABS Blend
Sensitivity Test Feature:	Automatic Sensitivity window verification test
Mounting:	Refer to NS Conventional Detector Base Data Sheet

APPLICATION

The SLR-24H can be used in all areas where Photoelectric Smoke Detectors are required. The wide range smoke chamber makes the SLR-24H well suited for fires ranging from smoldering to flaming fires.

NS-4 Series, NS-6 Series, HSC-4R or HSC-R Style bases may be used with the SLR-24H. Current interchangeable/compatible devices are the SIJ-24 ionization detector, SLR-24V photoelectric detector and the DCD-135°/190° heat detectors.

All NS conventional devices are mechanically compatible with Hochiki America HSB, HSC and YBA type bases which may have been used in previous installations. Please check individual panel listings for compatible bases.

OPERATION

The SLR-24H photoelectric smoke detector utilizes two bicolored LEDs for indication of status. In a normal standby condition the LEDs flash Green every 3 seconds. When the detector senses that its sensitivity has drifted outside the UL listed sensitivity window the LEDs will flash Red every 3 seconds. When the detector senses smoke and goes into alarm the status LEDs will latch on Red.

The detector utilizes an infrared LED light source and silicon photo diode receiving element in the smoke chamber. In a normal standby condition, the receiving element receives no light from the pulsing LED light source. In the event of a fire, smoke enters the detector smoke chamber and light is reflected from the smoke particles to the receiving element. The light received is converted into an electronic signal.

Signals are processed and compared to a reference level, and when two consecutive signals exceeding the reference level are received within a specified period of time, the time delay circuit triggers the SCR switch to activate the alarm signal. The status LEDs light continuously during the alarm period.

PRODUCT LISTINGS

Underwriters Laboratories: S1383
 CSFM #: 7272-0410:107
 Factory Mutual: 3006185

Specifications subject to change without notice.

Hochiki America Corporation

7051 Village Drive, Suite 100 • Buena Park, CA 90621-2268
 Phone: 714/522-2246 • Fax: 714/522-2268
 Technical Support: 800/845-6692 or technicalsupport@hochiki.com



ENGINEERING SPECIFICATIONS

The contractor shall furnish and install where indicated on the plans, Hochiki America Model SLR-24H photoelectric smoke detectors. The combination detector head and twist-lock base shall be UL listed compatible with a UL listed fire alarm panel.

The base shall permit direct interchange with Hochiki America SLR-24V photoelectric detector, SIJ-24 ionization type smoke detector and/or DCD-135°/190° fixed temperature/rate-of-rise heat detectors. The base shall be appropriate twist-lock base NS-4 Series, NS-6 Series, HSC-4R, or HSC-R. In the event of partial or complete retrofit, the SLR-24 may be used in conjunction with, or as a replacement for, Hochiki America detectors (SLK-24, SLK-24FH and the SIH-24) on most HSB and HSC base applications.

The smoke detector shall have two flashing status LEDs for visual supervision. When the detector is in standby condition the LEDs will flash Green. When the detector is outside the UL listed sensitivity window the LEDs will flash Red. When the detector is actuated, the flashing LEDs will latch on Red. The detector may be reset by actuating the control panel reset switch.

The sensitivity of the detector shall be capable of being measured. It shall be possible to perform a functional test of the detector without the need of generating smoke. The sensitivity of the detector shall be monitored automatically and continuously to verify that it is operating within the listed sensitivity range.

To facilitate installation, the detector shall be non-polarized. Voltage and RF transient suppression techniques shall be employed to minimize false alarm potential. Auxiliary SPDT relays shall be installed where indicated.

The vandal-resistant, security locking feature shall be used in those areas as indicated on the drawing. The locking feature shall be field removable when not required.

SLR-24H SENSITIVITY TEST FEATURE

The SLR-24H Photoelectric Smoke Detector has a built-in automatic sensitivity test feature.

1. In normal condition, both LED's flash green.
2. When the sensitivity drifts outside of its sensitivity limits, both LED's flash red.
3. In the alarm state both LED's are red continuously.
4. When the sensitivity drifts outside of its sensitivity limits and both LED's flash red, the device needs to be cleaned or returned to the factory for cleaning. Refer to HA Technical Bulletin HA-97 for cleaning information.

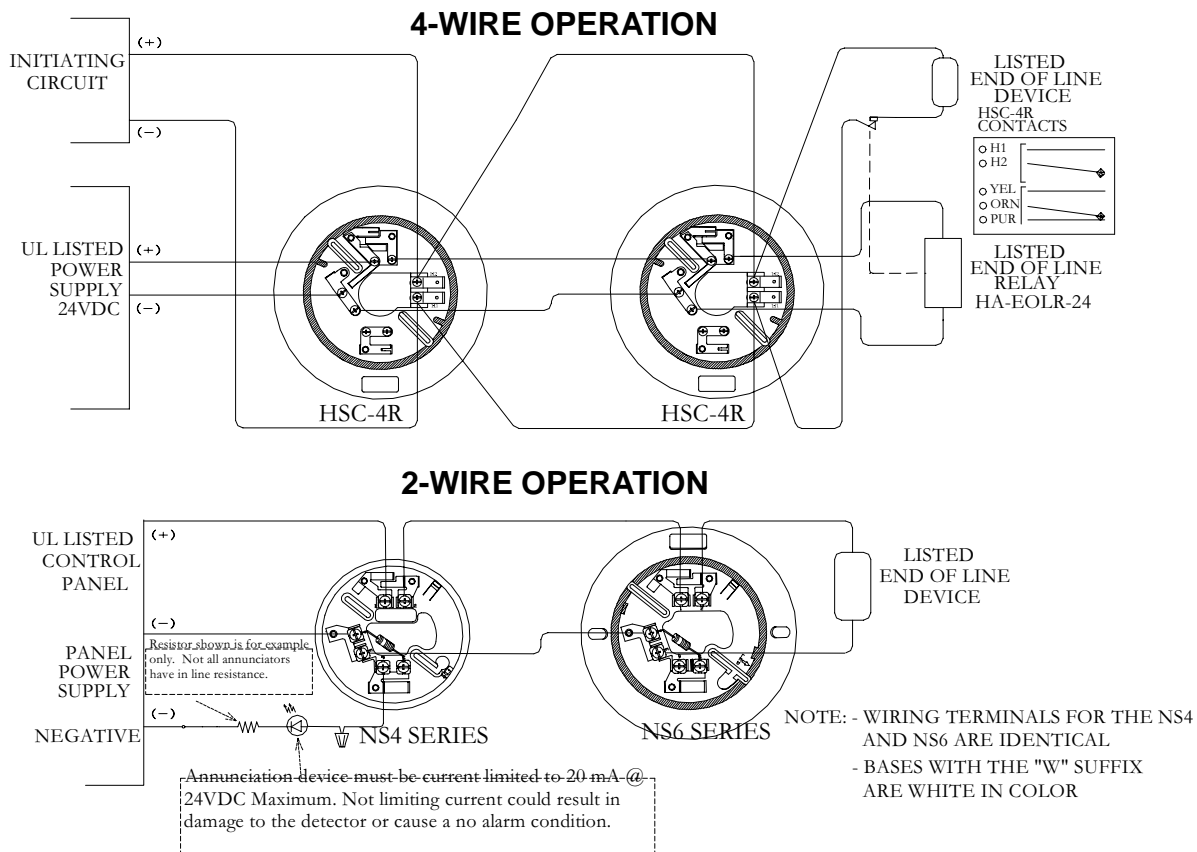

2-wire relay wiring diagram is also available