



**ALARM CHECK VALVE
8" MODEL H-1
FLANGE / FLANGE
8" MODEL H-3
FLANGE / GROOVE**

DESCRIPTION AND OPERATION

The Globe Model H-1 and H-3 8" Alarm Check Valves are used in wet pipe fire sprinkler systems. They primarily serve a dual purpose in that they prevent a reverse flow of water through their bodies (non-return) and also provide for the use of a hydraulic fire alarm which is not dependent upon an electrical power supply for its operation. Through the use of a hydraulic retard chamber a time delay is provided to eliminate potential false alarms caused by fluctuating water supply pressures. Where constant pressure water supplies are used the retard chamber (time delay) is not necessary. By incorporating the use of electrical pressure switches, other supplemental alarms, annunciators etc. may also be used.

Globe 8" Model H-1 and H-3 Alarm Check Valves may be installed in the vertical position and trim can be provided for both variable and constant water supply pressures.

The body of the Alarm Check Valve is constructed of high tensile strength cast iron having considerable ductility to reduce damage in field handling.

All interior operating parts are machined from highly corrosive-resistant alloys, each having high strength and good wear resistance.

Rubber parts are of selective materials which have good abrasive resistance and long life expectancy in terms of resiliency.



**MODEL H-1
ALARM CHECK VALVE**



**MODEL H-3
ALARM CHECK VALVE**

APPROVALS

- cULus Listed
- FM Approved

TECHNICAL DATA

- Water Working Pressure Rating - 175 psi (12 bars).
- Factory tested hydrostatically to 350 psi (24 bars).
- Equivalent feet of pipe: 8" Valve = 21 feet.

PHYSICAL DATA	MODEL	
	H-1	H-3
Overall Length	13 7/8"	15 1/8"
Weight of Valve	150 lbs.	130 lbs.
Complete with Vertical Variable Pressure Trimmings	200 lbs.	180 lbs.

ALARM CHECK VALVE
8" MODEL H-1
FLANGE / FLANGE
8" MODEL H-3
FLANGE / GROOVE

MODEL H-1
CROSS SECTION

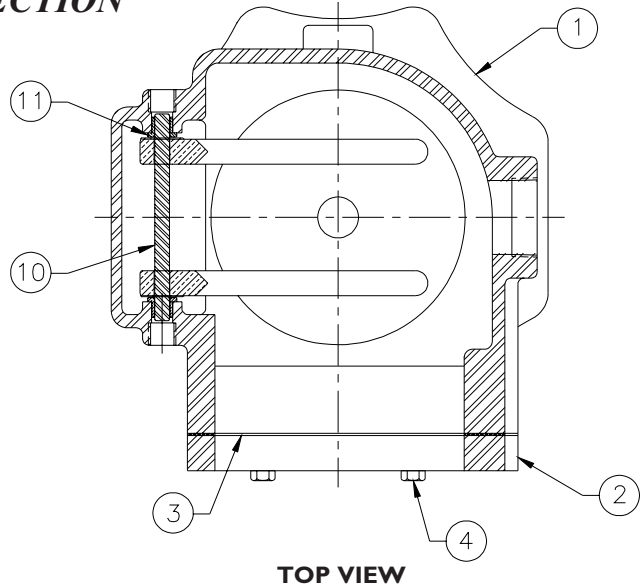
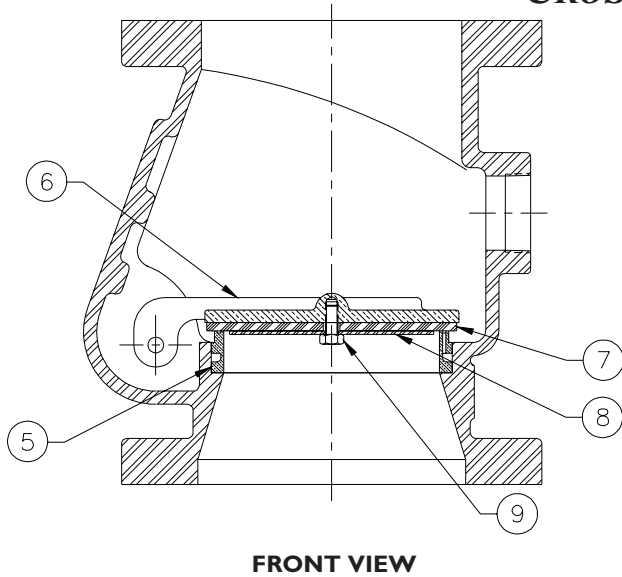

ITEM	DESCRIPTION	MAT'L	P/N	ITEM	DESCRIPTION	MAT'L	P/N
1	Body - H-1	Cast Iron	323832	7	Clapper Disc	EPDM	323842
	Body - H-3	Cast Iron	323851	8	Disc Retainer	Stainless	323843
2	Cover	Cast Iron	323835	9	Disc Retainer Bolt	Stainless	323838
3	Cover Gasket	Rubber	323833	10	Hinge Pin	Stainless	323845
4	Cover Bolt	Steel	323839	11	Hinge Pin Bushing	Bronze	323846
5	Seat Ring	Bronze	323837	12	Name Plate	Aluminum	323480
6	Clapper	Bronze	323841	13	Drive Screw	Stainless	323420

Refer to Globe's Alarm Check Valve Installation and Maintenance Guide (Bulletin A.C.V.I.M.) for trim set-up, installation instructions, and maintenance.

ORDERING INFORMATION

SPECIFY

- Quantity • Model Number • Size
- Factory Trimmed and Leak Tested Hydrostatically or Loose Trim for Customer Installation.

GLOBE® PRODUCT WARRANTY

Globe agrees to repair or replace any of its own manufactured products found to be defective in material or workmanship for a period of one year from date of shipment.

For specific details of our warranty please refer to Price List Terms and Conditions of Sale (Our Price List).



4077 AIRPARK DRIVE, STANDISH, MICHIGAN 48658
 989-846-4583 FAX 989-846-9231
 1-800-248-0278 www.globesprinkler.com