

Figure 513D (13D) and 513D/R (13D/R) Riser Manifolds 1, 1-1/2, and 2 Inch (DN25, DN40, and DN50) For NFPA 13D/13R Residential Sprinkler Systems

General Description

The Riser Manifolds described in this technical data sheet provide the necessary waterflow alarm, pressure gauge, and drain equipment in a single assembly for use in NFPA 13D or 13R residential sprinkler systems as follows:

NFPA 13D

- Figure 513D (13D)
1 Inch (DN25)
Female Thread x Female Thread

NFPA 13D/13R

- Figure 513D/R (13D/R)
1-1/2 Inch (DN40)
Male Thread x Female Thread
Male Thread x Male Thread
- Figure 513D/R (13D/R)
2 Inch (DN50)
Groove x Groove
Male Thread x Groove

The variety of sizes and end connections allow cost effective and easy transition to check valves, control valves, and system piping. The Riser Manifolds may be installed in either the horizontal (flow switch on top) or vertical (flow going up).

WARNING

The Riser Manifolds described herein must be installed and maintained in compliance with this document, as well as with the applicable standards of the National Fire Protection Association, in addition to the standards of any other authorities having jurisdiction. Failure to do so may impair the performance of these devices.

The owner is responsible for maintaining their fire protection system and devices in proper operating condition. The installing contractor or sprinkler manufacturer should be contacted with any questions.

Technical Data

Approvals

The Figure 513D (13D) and 513D/R (13D/R) Riser Manifolds with a cover tamper switch for the waterflow alarm switch are UL Listed, ULC Listed, and FM Approved.

The Figure 513D (13D) and 513D/R (13D/R) Riser Manifolds without a cover tamper switch for the waterflow alarm switch are UL Listed and FM Approved.

Maximum Working Pressure

175 psi (12,1 bar)

Assembly

The manifold body of the Figure 513 is ductile iron, whereas the manifold body of the Figure 13 is cast iron. The two assemblies are completely interchangeable in function, application, and end-to-end laying length.

Finish

Red painted.

Installation

The Riser Manifolds may be installed in either the horizontal (flow switch on top) or vertical (flow going up). The inlet of the Riser Manifold may be directly connected to a shut-off control valve.

NOTES

(1) Where applicable pipe thread sealant is to be applied sparingly. Use of a non-hardening pipe thread sealant is recommended.

(2) Provisions for an alarm test flow must be made. The alarm test flow is to be through an orifice having a flow capacity equal to or smaller than the smallest orifice sprinkler in the system. One of two options can be considered. The first option is to temporarily install a test orifice in the outlet of the drain



line prior to performing the alarm test. The second option is to install an Inspector's Test Connection downstream of the Waterflow Alarm Switch.

(3) Never remove any piping component nor correct or modify any piping deficiencies without first depressurizing and draining the system.

Step 1. Install the manifold body with the flow arrow pointing in the downstream position using threaded connections and/or listed mechanical grooved connections, as applicable.

Step 2. Connect the drain line, and then close the drain valve.

Step 3. Refer to Figure 4 for wiring guidance. All wiring must be performed in accordance with the Authority Having Jurisdiction and/or the National Electrical Code.

Step 4. Place the system in service by filling the system with water. When filling the system, partially open the control valve to slowly fill the system. Filling the system slowly will help avoid damaging the waterflow alarm switch.

After the system is fully pressurized, completely open the control valve.

Step 5. Secure all supply valves open.

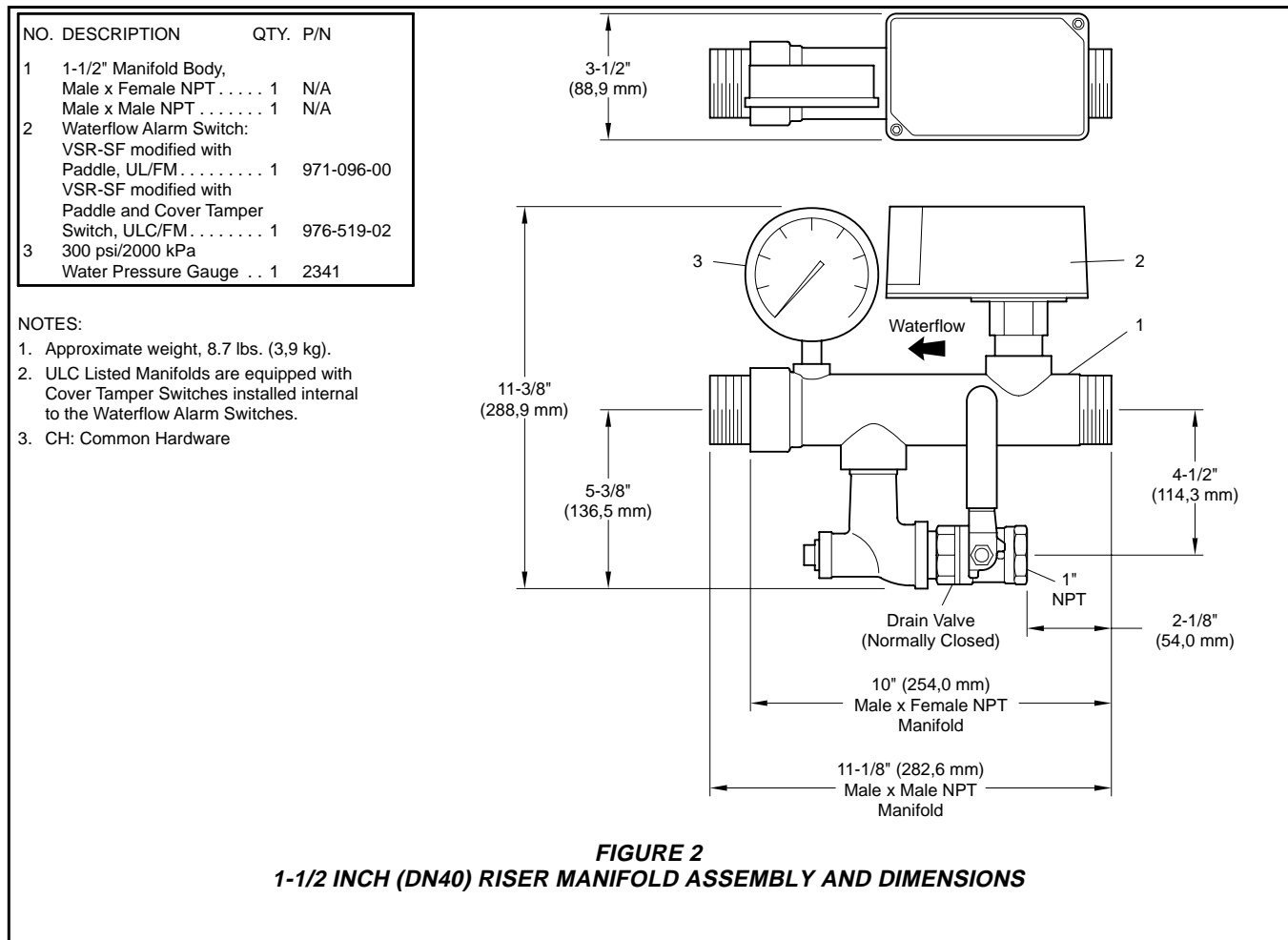
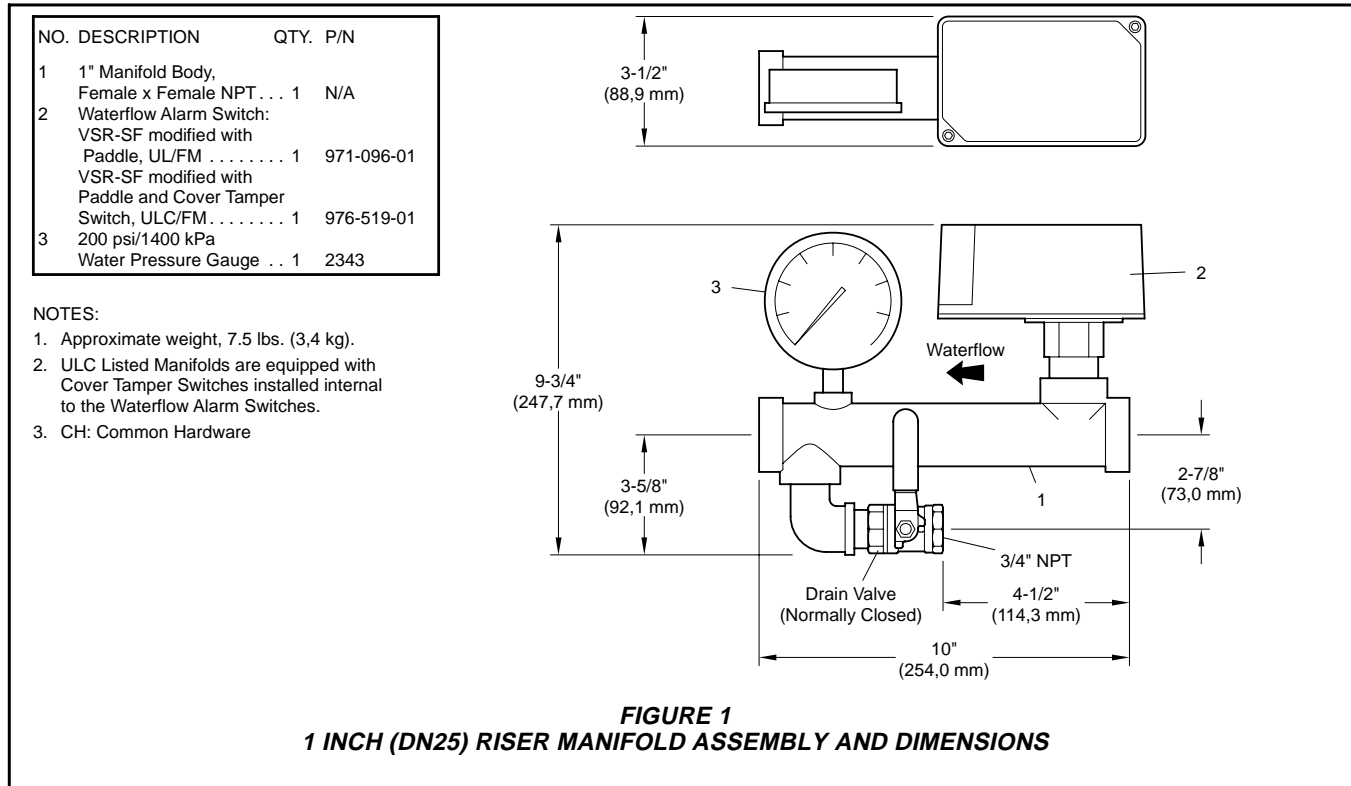

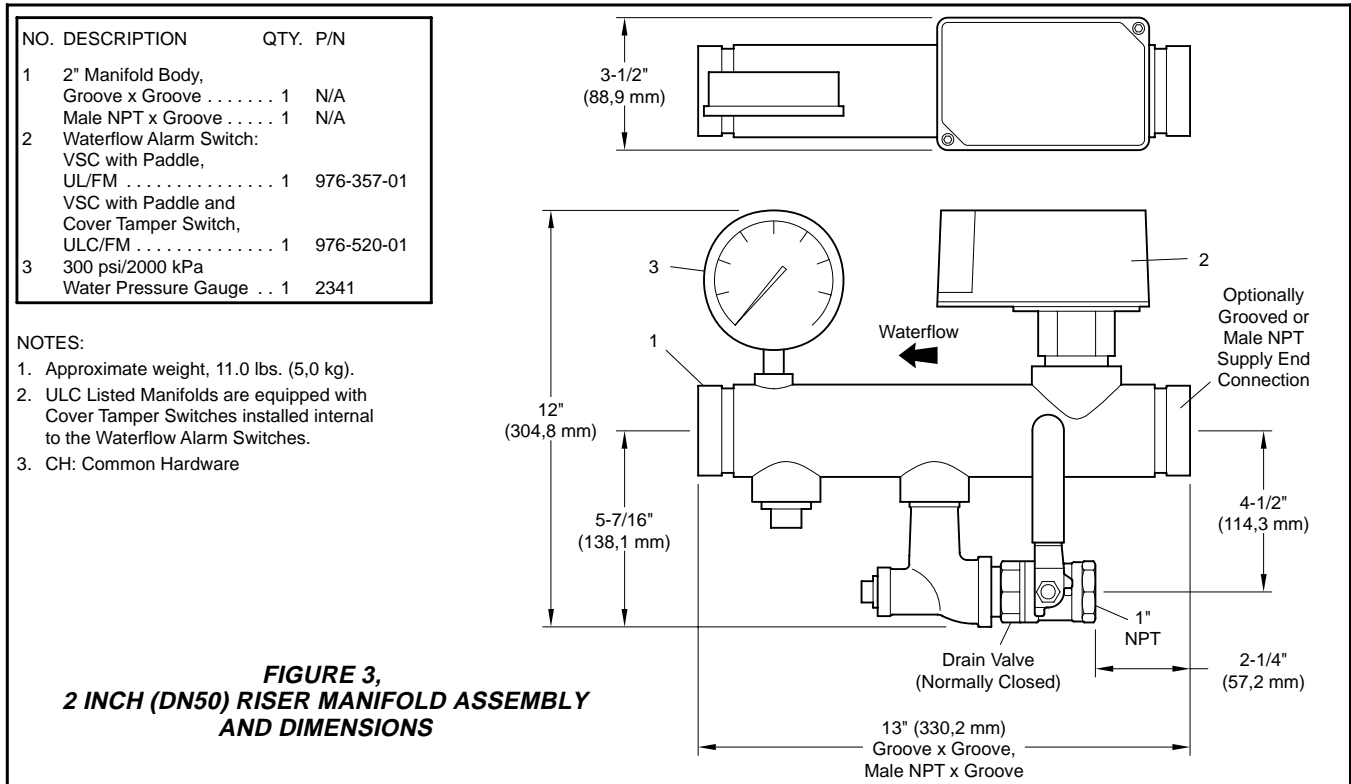

Care and Maintenance

The following inspection procedure must be performed as indicated, in addition to any specific requirements of the NFPA, and any impairment must be immediately corrected.

The owner is responsible for the inspection, testing, and maintenance of their fire protection system and devices in compliance with this document, as well as with the applicable standards of the National Fire Protection Association (e.g., NFPA 25), in addition to the standards of any authority having jurisdiction. The installing contractor or product manufacturer should be contacted relative to any questions.

It is recommended that automatic sprinkler systems be inspected, tested, and maintained by a qualified Inspection Service in accordance with local requirements and/or national codes.

NOTES

No attempt is to be made to repair any Riser Manifold component in the field. Only the pressure gauge or waterflow alarm switch can be replaced. If any other problems are encountered the entire riser manifold must be replaced.

The flow and alarm test procedure will

result in operation of the associated alarms. Consequently, notification must be given to the owner and the fire department, central station, or other signal station to which the alarms are connected, and notification must be given to the building occupants.

Before closing a fire protection system control valve for inspection or maintenance work on the fire protection system that it controls, permission to shut down the effected fire protection system must first be obtained from the proper authorities and all personnel who may be affected by this action must be notified.

After placing a fire protection system in service, notify the proper authorities and advise those responsible for monitoring proprietary and/or central station alarms.

Flow Test Procedure

Step 1. Fully open the drain valve. Make certain that drainage water will not cause any damage or injury.

Step 2. Verify that the residual (flowing) pressure indicated by the pressure gauge is no less than originally recorded for the system when it was first installed.

Step 3. Close the drain valve.

Step 4. Verify that the static (not flowing) pressure indicated by the pressure gauge is no less than originally

recorded for the system when it was first installed.

Alarm Test Procedure With A Test Orifice (See Installation Note 2)

Step 1. Temporarily install a test orifice in the drain line outlet.

Step 2. Fully open the drain valve. Make certain that drainage water will not cause any damage or injury.

Step 3. Verify operation of the associated alarms.

Step 3. Close the drain valve.

Step 4. Remove the test orifice from the drain line outlet.

Alarm Test Procedure With An Inspector's Test Connection (See Installation Note 2)

Step 1. Fully open the Inspector's Test Connection Valve. Make certain that drainage water will not cause any damage or injury.

Step 2. Verify operation of the associated alarms.

Step 3. Close the Inspector's Test Connection Valve.

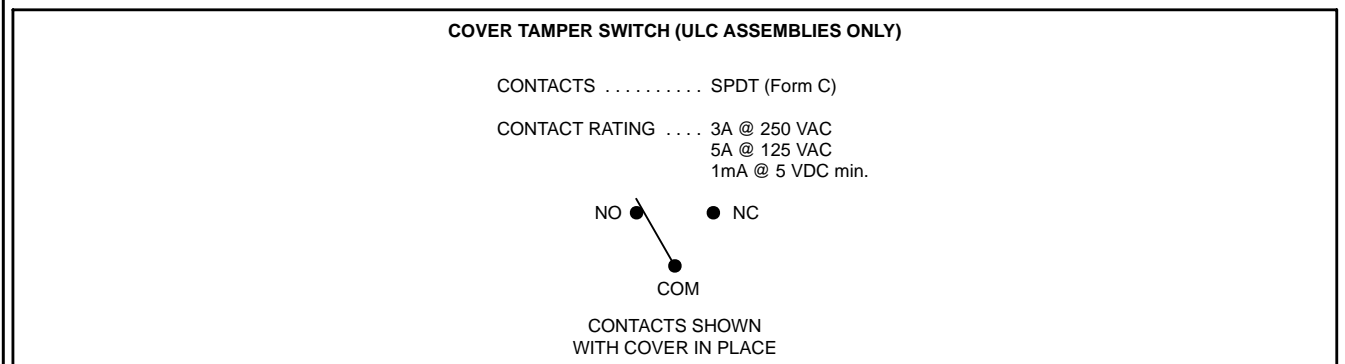
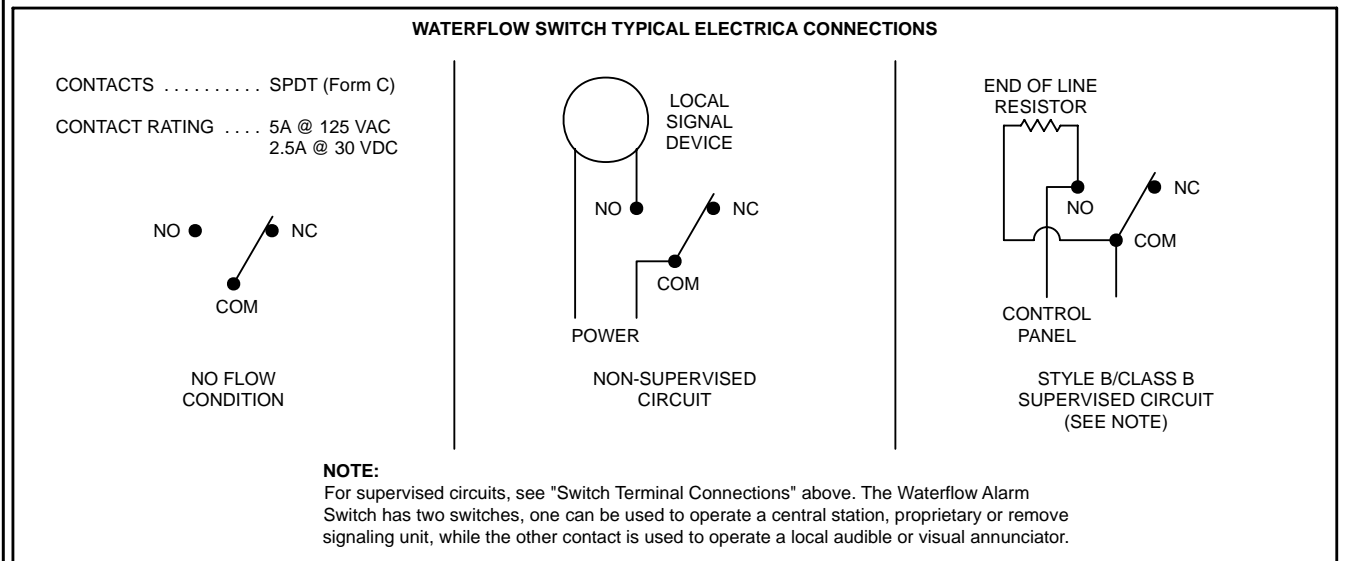
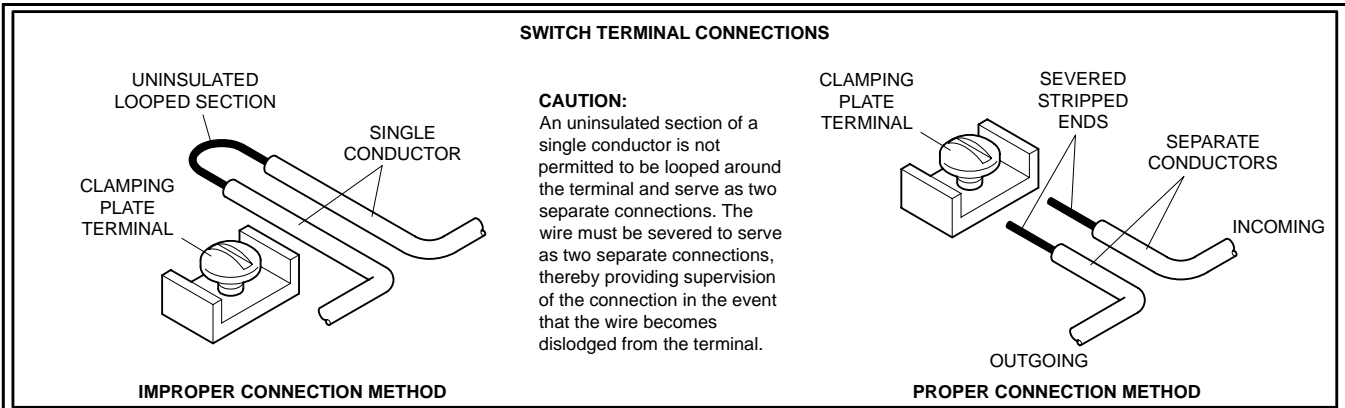

**FIGURE 4
WIRING GUIDANCE**

Limited Warranty

Products manufactured by Tyco Fire & Building Products (TFBP) are warranted solely to the original Buyer for ten (10) years against defects in material and workmanship when paid for and properly installed and maintained under normal use and service. This warranty will expire ten (10) years from date of shipment by TFBP. No warranty is given for products or components manufactured by companies not affiliated by ownership with TFBP or for products and components which have been subject to misuse, improper installation, corrosion, or which have not been installed, maintained, modified or repaired in accordance with applicable Standards of the National Fire Protection Association, and/or the standards of any other Authorities Having Jurisdiction. Materials found by TFBP to be defective shall be either repaired or replaced, at TFBP's sole option. TFBP neither assumes, nor authorizes any person to assume for it, any other obligation in connection with the sale of products or parts of products. TFBP shall not be responsible for sprinkler system design errors or inaccurate or incomplete information supplied by Buyer or Buyer's representatives.

In no event shall TFBP be liable, in contract, tort, strict liability or under any other legal theory, for incidental, indirect, special or consequential damages, including but not limited to labor charges, regardless of whether TFBP was informed about the possibility of such damages, and in no event shall TFBP's liability exceed an amount equal to the sales price.

The foregoing warranty is made in lieu of any and all other warranties, express or implied, including warranties of merchantability and fitness for a particular purpose.

This limited warranty sets forth the exclusive remedy for claims based on failure of or defect in products, materials or components, whether the claim is made in contract, tort, strict liability or any other legal theory.

This warranty will apply to the full extent permitted by law. The invalidity, in whole or part, of any portion of this warranty will not affect the remainder.

Ordering Information

Riser Manifold:

Specify; Size (specify), Figure (specify 513D or 513D/R, (specify connection type inlet x outlet) Riser Manifold (specify - without or with) a cover tamper switch for the waterflow alarm switch, P/N (specify).

NOTES

Orders for Figure 513D or 513D/R may be filled with a Figure 13D or 13D/R, respectively. The two assemblies are completely interchangeable in function, application, and end-to-end laying length.

If a ULC Listing is required, the Riser Manifold must be ordered with a cover tamper switch for the waterflow alarm switch.

UL/ULC/FM Assemblies

With Cover Tamper Switch

1 Inch (DN25)	
FT x FT	P/N 4085
1-1/2 Inch (DN40)	
MT x FT	P/N 4088
1-1/2 Inch (DN40)	
MT x MT	P/N 4089
2 Inch (DN50)	
G x G	P/N 4093
2 Inch (DN50)	
MT x G	P/N 4094

UL/FM Assemblies

Without Cover Tamper Switch

1 Inch (DN25)	
FT x FT	P/N 4047
1-1/2 Inch (DN40)	
MT x FT	P/N 4057
1-1/2 Inch (DN40)	
MT x MT	P/N 4058
2 Inch (DN50)	
G x G	P/N 4059
2 Inch (DN50)	
MT x G	P/N 4064

Replacement Parts:

Specify: (description) for use with Figure 513D, 513D/R, 13D, or 13D/R Riser Manifold, P/N (Ref. Figure 1, 2 or 2, as applicable).

