



TECHNICAL DATA

**MODEL J-1 FM APPROVED
ALARM CHECK VALVE VERTICAL
TRIM FOR EUROPEAN MARKET**

The Viking Corporation, 210 N Industrial Park Road, Hastings MI 49058

Telephone: 269-945-9501 Technical Services 877-384-5464 Fax: 269-945-4495 Email: techsvcs@vikingcorp.com

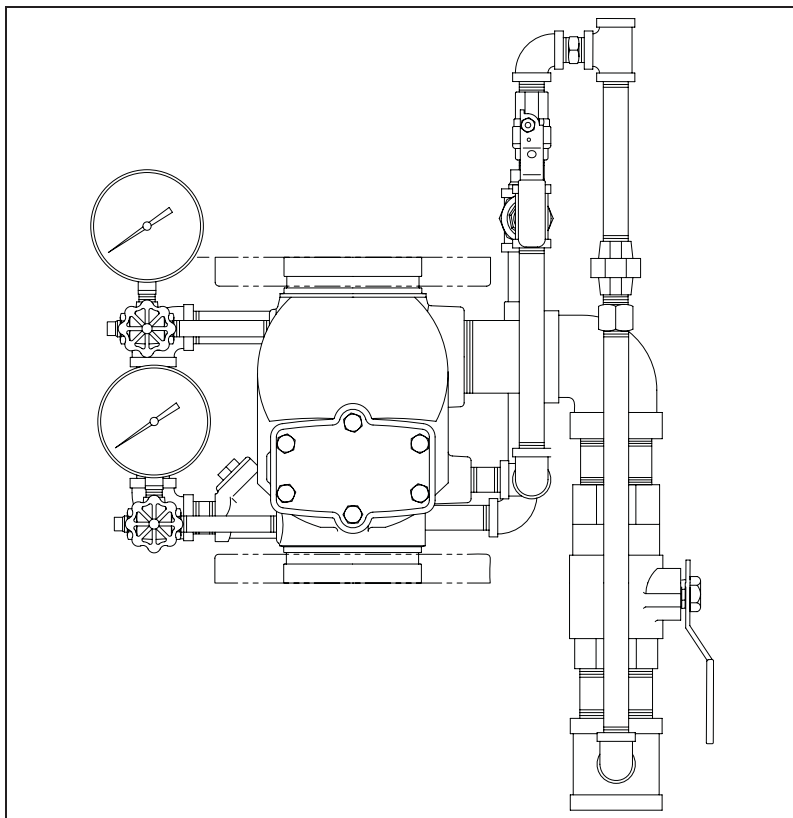

FM Approved Model J-1 Alarm Check Valve Trim for European Market

Valve Size	Trim Part Number
DN80	08633-L
DN100	08634-L
DN150	08635-L
DN200	08636-L

Standard Trim Sets include galvanized nipples and fittings.

Notes: For use with Trim Chart on Page 27b_Euro

General Notes:

- Valve must be trimmed as shown. Any deviation from trim size or arrangement may affect the proper operation of the valve.
- All pipe, 3/4" (20mm) and smaller, shall be galvanized steel.
- Viking uses ANSI tee designations in all trim callouts.

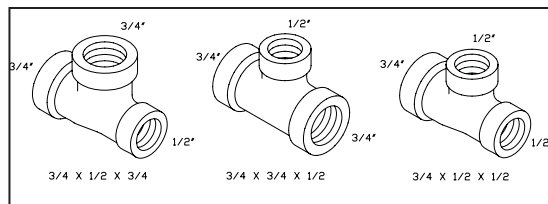

Note 1: When using a water motor alarm, a strainer is required. Circuit closer vent trim may be required when an alarm pressure switch is used. (See technical data for the retard chamber.)

Note 2: This location may be used for optional pressure relief valve (not available from Viking). Install 3/4" (20 mm) tee and listed pressure relief valve.

Note 3: To supply an optional excess pressure pump (not available from Viking and not a listed assembly), replace 1/2" ell marked "A" with a tee. Replace 3/4" ell marked "B" with a tee to connect outlet from excess pressure pump. Do not exceed listed water working pressure rating of system components. Perform hydrostatic tests in accordance with recognized Installation Standards.

Note 4: Location for non-interruptible pressure switch. When waterflow through the alarm valve occurs, supply to this location cannot be shut off until water flow through the alarm valve stops.

Note 5: Component specified is included in Viking trim sets; do not substitute. Use of components other than specified will void any listings and approvals and may affect operation of the valve.

Note 6: 300 PSI (20.7 bar) water pressure gauges are provided with trim. 600 PSI (41.4 bar) water pressure gauges are available. Order separately when needed*. Refer to current Viking Price Book.

* NFPA 13 requires gauges to have a minimum limit not less than twice the normal water working pressure at the point where the gauges are installed. When normal water working pressure exceeds 150 PSI (10.3 bar), order 600 PSI (41.4 bar) water pressure gauges separately.



TECHNICAL DATA

MODEL J-1 FM APPROVED ALARM CHECK VALVE VERTICAL TRIM FOR EUROPEAN MARKET

The Viking Corporation, 210 N Industrial Park Road, Hastings MI 49058

Telephone: 269-945-9501 Technical Services 877-384-5464 Fax: 269-945-4495 Email: techsvcs@vikingcorp.com

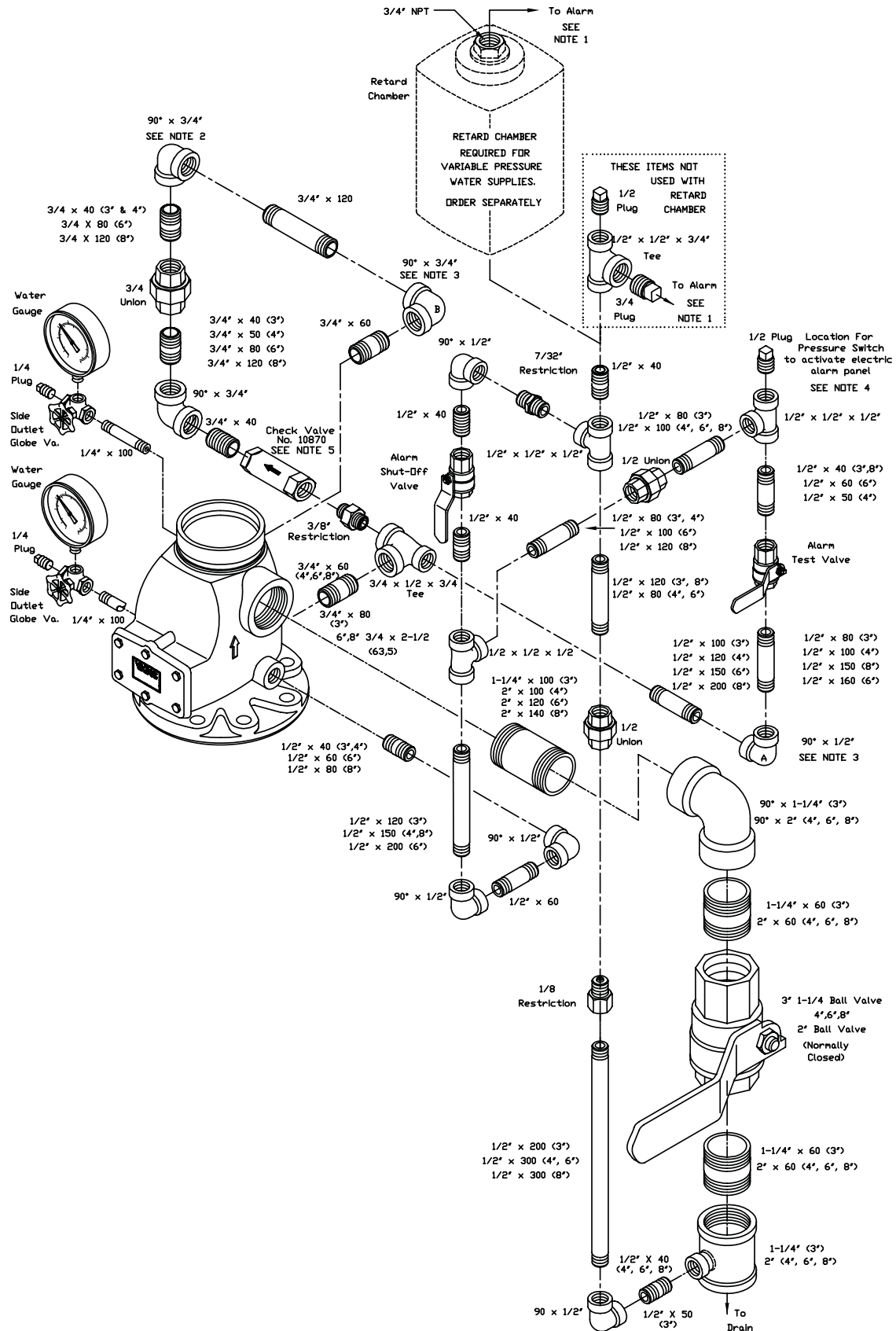



TECHNICAL DATA

**MODEL J-1 FM APPROVED
ALARM CHECK VALVE VERTICAL
TRIM FOR EUROPEAN MARKET**

The Viking Corporation, 210 N Industrial Park Road, Hastings MI 49058

Telephone: 269-945-9501 Technical Services 877-384-5464 Fax: 269-945-4495 Email: techsvcs@vikingcorp.com

Model J-1 Alarm Check Valve Vertical Trim, and Pressure Switches Must be Ordered Separately Refer to Technical Data.

All dimensions are approximations. Dimensions in parentheses are millimeter.

SIZE	A	B	C	D	E	F	G	H	K	L	M	R
3" (DN80)	10-1/8 (257)	7-1/4 (184)	7-3/4 (197)	7-3/4 (197)	10-1/8 (257)	11-3/4 (298)	5 (127)	6-1/2 (165)	7-1/4 (184)	10 (254)	5-1/2 (140)	11 (279)
4" (DN100)	10-5/8 (270)	7-1/2 (191)	9 (229)	9 (229)	12-1/4 (311)	12-3/8 (314)	5-1/2 (140)	6-1/4 (159)	8-3/4 (222)	10 (254)	6-1/2 (165)	12-1/2 (318)
6" (DN150)	13-3/8 (340)	10-1/4 (260)	9-3/4 (248)	9-3/4 (248)	13 (330)	11-1/4 (286)	6 (153)	8-3/4 (222)	9-1/4 (235)	11 (279)	7 (178)	12-1/2 (318)
8" (DN200)	17 (432)	8-1/4 (210)	11 (279)	10-1/2 (267)	14-1/4 (362)	6-3/4 (171)	6-1/2 (165)	10 (254)	10-7/8 (276)	12 (305)	7-1/2 (191)	12-1/2 (318)

MODEL J-1 ALARM CHECK VALVE WITH VERTICAL TRIM FOR CONSTANT PRESSURE WATER SUPPLY

All dimensions are approximations. Dimensions in parentheses are millimeter.

SIZE	A	B	C	D	E	F	G	H	J	K	L	M	N	O	P	R
3" (DN80)	10-1/8 (257)	7-1/4 (184)	7-3/4 (197)	7-3/4 (197)	10-1/8 (257)	11-3/4 (298)	5 (127)	6-1/2 (165)	11-3/4 (299)	7-1/4 (184)	10 (254)	5-1/2 (140)	5-7/8 (149)	28-1/8 (714)	4-3/4 (121)	11 (279)
4" (DN100)	10-5/8 (270)	7-1/2 (191)	9 (229)	9 (229)	12-1/4 (311)	12-3/8 (314)	5-1/2 (140)	6-1/4 (159)	13-3/8 (340)	8-3/4 (222)	10 (254)	6-1/2 (165)	5-7/8 (149)	28-5/8 (733)	5-1/4 (134)	12-1/2 (318)
6" (DN150)	13-3/8 (340)	10-1/4 (260)	9-3/4 (248)	9-3/4 (248)	13 (330)	11-1/4 (286)	6 (153)	8-3/4 (222)	14-1/8 (359)	9-1/4 (235)	11 (279)	7 (178)	5-7/8 (149)	28 (711)	7 (178)	12-1/2 (318)
8" (DN200)	17 (432)	8-1/4 (210)	11 (279)	10-1/2 (267)	14-1/4 (362)	6-3/4 (171)	6-1/2 (165)	10 (254)	16-1/4 (413)	10-7/8 (276)	12 (305)	7-1/2 (191)	5-7/8 (149)	23-5/8 (600)	9 (229)	12-1/2 (318)

Model J-1 Alarm Check Valve, Vertical Trim, Retard Chamber, Pressure Switches, and Circuit Closer Vent Trim Must be Ordered Separately Refer to Technical Data.

J-1 ALARM CHECK VALVE WITH VERTICAL TRIM, RETARD CHAMBER, AND PRESSURE SWITCH FOR VARIABLE PRESSURE WATER SUPPLY

**THIS PAGE
INTENTIONALLY
LEFT BLANK**