

Sprinkler

ESFR Sprinkler

Paradise ESFR sprinkler (Early Suppression Fast Response Sprinkler) has been designed to meet high challenging fire hazards such as large storages and warehouses. Fast reponse combined with larger water droplet size and velocity provides early and effective suppression of high challenging fires. It is particularly ideal for inflammable material storage.

Operation

As the ambient temperature rises up to the working temperature, the special liquid contained within ESFR sprinkler starts to expand to break open the glass bulb to release water.

Specification

Model No.	FH921	FH922
Working Temperature	68°C	93°C
Max. Ambient Temperature	39°C	57°C
Std. Material	BC6	
Connection Screw Size	20A (PT 3/4 ")	
Orifice Size	ø 17.9mm	
Test Pressure	35kgf/cm ²	
Flow Rate	203ℓ /min-1 kgf/cm ² (K=203±8)	
Weight	14kg/Box	
Packaging	50Ea	



Pendent

Assembly Diagram

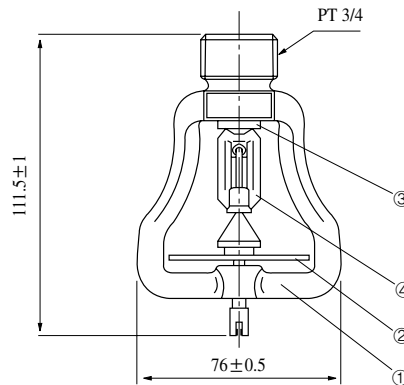

NO	Part	Material
1	Frame	Cast Bronze
2	Deflector	Phosphor Copper
3	Gasket Holder	Brass
4	Supporter	Phosphor Copper