

Sprinkler

Open Type Sprinkler

As the all-time open head without heat sensing part suitable for deluge system, Paradise **Open type** sprinkler is widely used for factory, special industrial facility, underground shopping area, and hazardous material storage.



Open Pendant Type



Open Upright Type

Specification

Model No.	(FH110-1) / FH120-1(Casting) (FH110-2) / FH120-2(Forging)	(FH140-1) / FH150-1(Casting) (FH140-2) / FH150-2(Forging)
Connection Screw Size	15A (PT 1/2 ")	20A (PT 3/4 ")
Orifice Size	ø 11.1mm	ø 13.5mm
Flow Rate	80ℓ /min-1kgf/cm ² (K=80)	114ℓ /min-1kgf/cm ² (K=114)
Weight	7kg/Box	9kg/Box
Packaging	100Ea	

※ Number in () represents **Upright type** model number.

Assembly Diagram

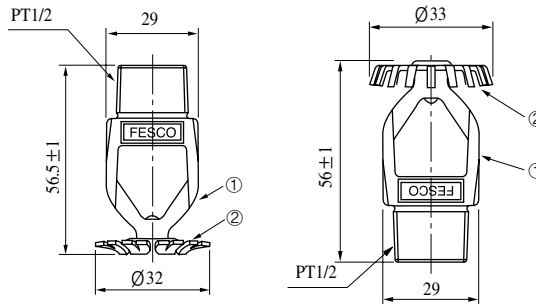

NO	Part	Material
1	Frame	Cast or Forged Brass
2	Deflector	Brass

Installation Diagram

