

Series LFII Residential, NFPA 13 Optimized Horizontal Sidewall Sprinklers 5.6 K-factor

General Description

The Series LFII (TY3334) Residential Horizontal Sidewall Sprinklers are decorative, fast response, frangible bulb sprinklers designed for use in residential occupancies such as homes, apartments, dormitories, and hotels. When enhanced flow characteristics for residential portions of any occupancy per NFPA 13 is the major consideration, the Series LFII (TY3334) should be the first choice.

When higher flow demands are required for residential sprinklers used in an NFPA 13 design, the large 5.6 K-factor of the Series LFII (TY3334) is an attractive choice. Although mostly intended where residential sprinklers are to be used in an NFPA 13 design, the Series LFII (TY3334) can also be used in wet pipe residential sprinkler systems for one- and two-family dwellings and mobile homes per NFPA 13D, and wet pipe residential sprinkler systems for residential occupancies up to and including four stories in height per NFPA 13R.

The recessed version of the Series LFII (TY3334) is intended for use in areas with finished walls. It employs a two-piece Style 20 Recessed Escutcheon. The Recessed Escutcheon provides 1/4 inch (6,4 mm) of recessed

adjustment or up to 1/2 inch (12,7 mm) of total adjustment from the flush mounting surface position. The adjustment provided by the Recessed Escutcheon reduces the accuracy to which the pipe nipples to the sprinklers must be cut.

The Series LFII (TY3334) has been designed with heat sensitivity and water distribution characteristics proven to help in the control of residential fires and to improve the chance for occupants to escape or be evacuated.

WARNINGS

*The Series LFII (TY3334) Residential Horizontal Sidewall Sprinklers described herein must be installed and maintained in compliance with this document, as well as with the applicable standards of the National Fire Protection Association, in addition to the standards of any other authorities having jurisdiction. **Failure to do so may impair the performance of these devices.***

The owner is responsible for maintaining their fire protection system and devices in proper operating condition. The installing contractor or sprinkler manufacturer should be contacted with any questions.



Sprinkler/Model Identification Number

SIN TY3334

IMPORTANT

Always refer to Technical Data Sheet TFP700 for the "INSTALLER WARNING" that provides cautions with respect to handling and installation of sprinkler systems and components. Improper handling and installation can permanently damage a sprinkler system or its components and cause the sprinkler to fail to operate in a fire situation or cause it to operate prematurely.

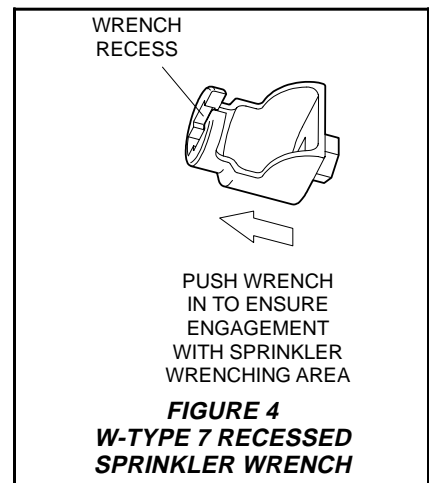
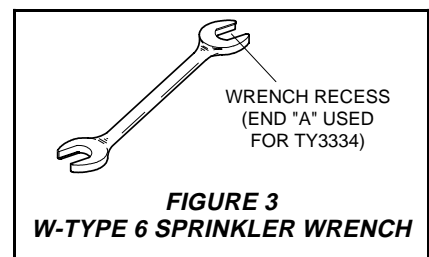
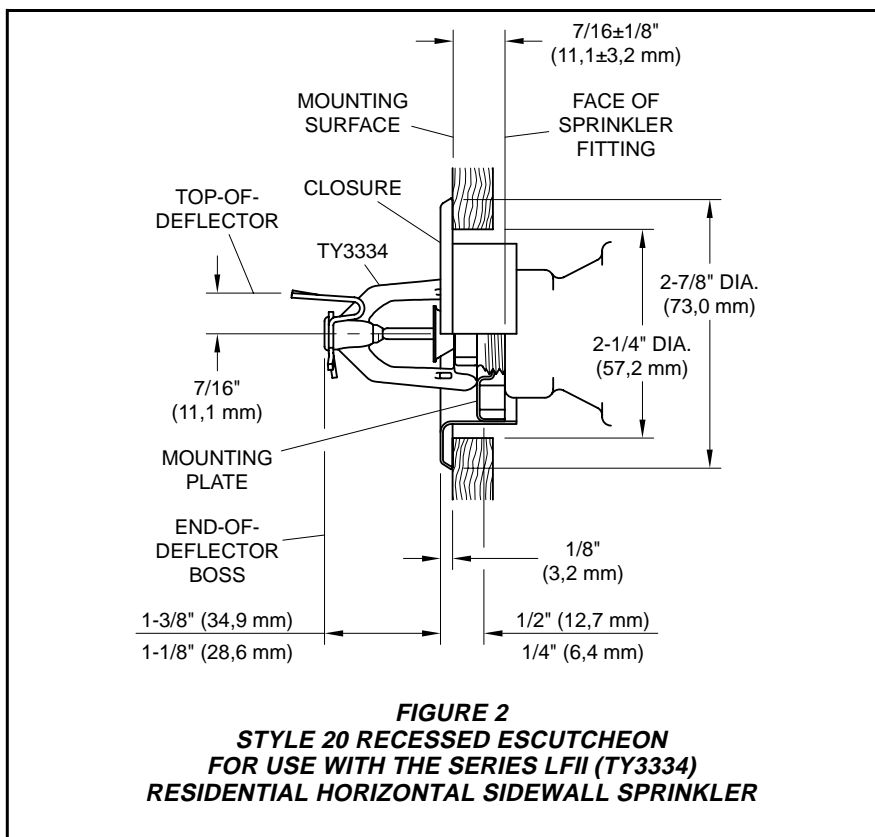
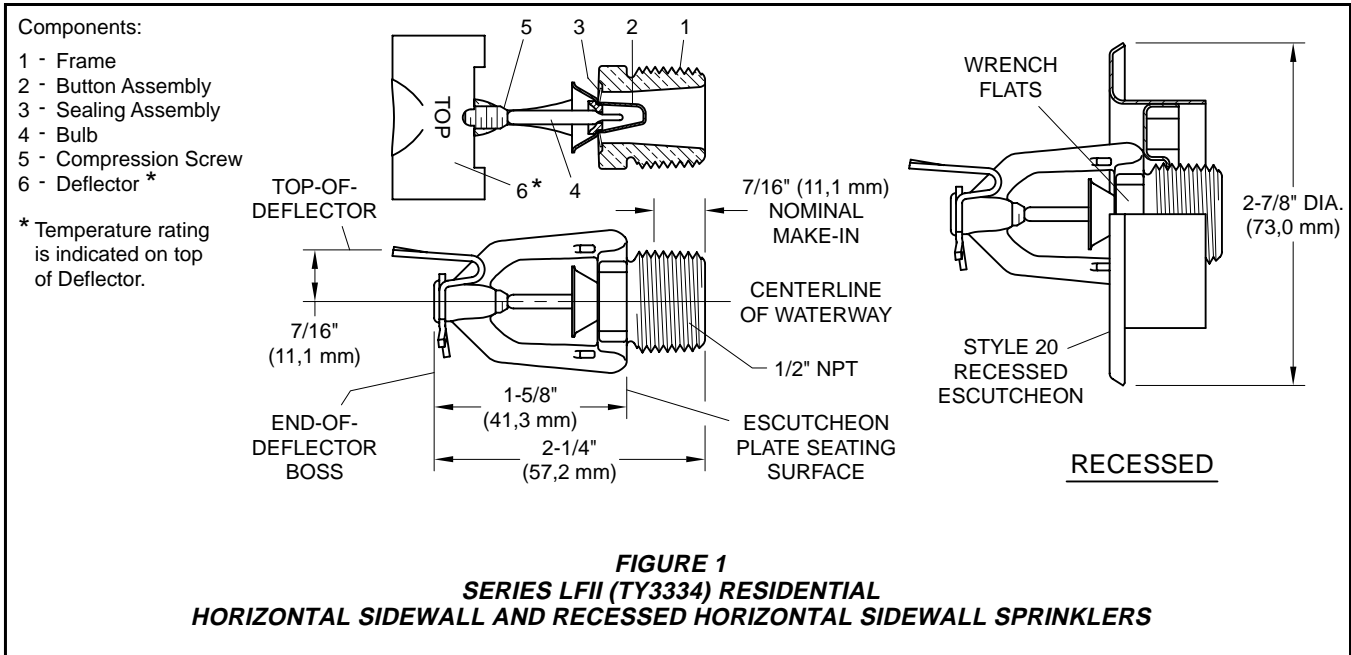

Technical Data

Approvals:
 UL and C-UL Listed.

Maximum Working Pressure:
 175 psi (12,1 bar)

Discharge Coefficient:
 K = 5.6 GPM/psi^{1/2} (80,6 LPM/bar^{1/2})

Temperature Rating:
 155°F/68°C or 175°F/79°C

Finishes:
 White Polyester Coated,
 Chrome Plated, or Natural Brass

Physical Characteristics:

Frame	Brass
Button	Bronze
Sealing Assembly	Beryllium Nickel w/Teflon†
Bulb	3 mm dia. Glass
Compression Screw	Bronze
Deflector	Copper

†Dupont Registered Trademark

Operation

The glass Bulb contains a fluid that expands when exposed to heat. When the rated temperature is reached, the fluid expands sufficiently to shatter the glass Bulb allowing the sprinkler to activate and flow water.

Design Criteria

The Series LFII (TY3334) Residential Horizontal Sidewall Sprinklers are UL and C-UL Listed for installation in accordance with the following criteria.

NOTE

When conditions exist that are outside the scope of the provided criteria, refer to the Residential Sprinkler Design Guide TFP490 for the manufacturer's recommendations that may be acceptable to the local Authority Having Jurisdiction.

System Type. Only wet pipe systems may be utilized.

Hydraulic Design. The minimum required sprinkler flow rate for systems designed to NFPA 13D or NFPA 13R are given in Table A and B as a function of temperature rating and the maximum allowable coverage areas. The sprinkler flow rate is the minimum required discharge from each of the total number of "design sprinklers" as specified in NFPA 13D or NFPA 13R.

For systems designed to NFPA 13, the number of design sprinklers is to be the four most hydraulically demanding sprinklers. The minimum required discharge from each of the four sprinklers is to be the greater of the following:

- The flow rates given in Tables A and B for NFPA 13D and 13R as a function of temperature rating and the maximum allowable coverage area.
- A minimum discharge of 0.1 gpm/sq. ft. over the "design area" comprised of the four most hydraulically demanding sprinklers for the actual coverage areas being protected by the four sprinklers.

Obstruction To Water Distribution. Locations of sprinklers are to be in accordance with the obstruction rules of NFPA 13 for residential sprinklers.

Operational Sensitivity. The sprinklers are to be installed with an end-of-deflector-boss to wall distance of 1-3/8 to 6 inches or in the recessed position using only the Style 20 Recessed Escutcheon as shown in Figure 2.

In addition the top-of-deflector-to-ceiling distance is to be within the range (Ref. Table A or B) being hydraulically calculated.

Sprinkler Spacing. The minimum spacing between sprinklers is 8 feet (2,4 m) when installed with a top-of-deflector-to-ceiling distance of 4 to 6 inches (100 to 150 mm). The minimum spacing between sprinklers is 9 feet (2,7 m) when installed with a top-of-deflector-to-ceiling distance of 6 to 12 inches (150 to 300 mm). The maximum spacing between sprinklers cannot exceed the width of the coverage area (Ref. Table A) being hydraulically calculated (e.g., maximum 12 feet for a 12 ft. x 12 ft. coverage area, or 16 feet for a 16 ft. x 20 ft. coverage area).

Installation

The Series LFII (TY3334) must be installed in accordance with the following instructions:

NOTES

Do not install any bulb type sprinkler if the bulb is cracked or there is a loss of liquid from the bulb. With the sprinkler held horizontally, a small air bubble should be present. The diameter of the air bubble is approximately 1/16 inch (1,6 mm).

A leak tight 1/2 inch NPT sprinkler joint should be obtained with a torque of 7 to 14 ft.lbs. (9,5 to 19,0 Nm). A maximum of 21 ft.lbs. (28,5 Nm) of torque is to be used to install sprinklers. Higher levels of torque may distort the sprinkler inlet with consequent leakage or impairment of the sprinkler.

Do not attempt to compensate for insufficient adjustment in an Escutcheon Plate by under- or over-tightening the Sprinkler. Readjust the position of the sprinkler fitting to suit.

The Series LFII Horizontal Sidewall Sprinklers must be installed in accordance with the following instructions.

Step 1. Horizontal sidewall sprinklers are to be installed in the horizontal position with their centerline of waterway perpendicular to the back wall and parallel to the ceiling. The word "TOP" on the Deflector is to face towards the ceiling with the front edge of the Deflector parallel to the ceiling.

Step 2. With pipe thread sealant applied to the pipe threads, hand tighten the sprinkler into the sprinkler fitting.

Step 3. Tighten the sprinkler into the sprinkler fitting using only the W-Type 6 Sprinkler Wrench (Ref. Figure 3). With reference to Figure 1, the W-Type

6 Sprinkler Wrench is to be applied to the wrench flats.

The **Series LFII Recessed Horizontal Sidewall Sprinklers** must be installed in accordance with the following instructions.

Step A. Recessed horizontal sidewall sprinklers are to be installed in the horizontal position with their centerline of waterway perpendicular to the back wall and parallel to the ceiling. The word "TOP" on the Deflector is to face towards the ceiling.

Step B. After installing the Style 20 Mounting Plate over the sprinkler threads and with pipe thread sealant applied to the pipe threads, hand tighten the sprinkler into the sprinkler fitting.

Step C. Tighten the sprinkler into the sprinkler fitting using only the W-Type 7 Recessed Sprinkler Wrench (Ref. Figure 4). With reference to Figure 1, the W-Type 7 Recessed Sprinkler Wrench is to be applied to the sprinkler wrench flats.

Step C. After the wall has been installed or the finish coat has been applied, slide on the Style 20 Closure over the Series LFII Sprinkler and push the Closure over the Mounting Plate until its flange comes in contact with the wall.

Care and Maintenance

The Series LFII (TY3334) must be maintained and serviced in accordance with the following instructions:

NOTES

Absence of an Escutcheon Plate may delay the sprinkler operation in a fire situation.

Before closing a fire protection system main control valve for maintenance work on the fire protection system which it controls, permission to shut down the affected fire protection system must be obtained from the proper authorities and all personnel who may be affected by this action must be notified.

Sprinklers which are found to be leaking or exhibiting visible signs of corrosion must be replaced.

Automatic sprinklers must never be painted, plated, coated, or otherwise altered after leaving the factory. Modified sprinklers must be replaced. Sprinklers that have been exposed to corrosive products of combustion, but have not operated, should be replaced if they cannot be completely cleaned



ELEVATION

Maximum Coverage Area ^(a) Width x Length ^(b) Ft. x Ft. (m x m)	Maximum Spacing Ft. (m)	Minimum Flow ^(c) and Residual Pressure			
		Top-Of-Deflector- To- Ceiling: 4 to 6 Inches (100 to 150 mm)		Top-Of-Deflector- To- Ceiling: 6 to 12 Inches (150 to 300 mm)	
		155°F/68°C	175°F/79°C	155°F/68°C	175°F/79°C
12 x 12 (3,7 x 3,7)	12 (3,7)	17 GPM (64,3 LPM) 9.2 psi (0,63 bar)	17 GPM (64,3 LPM) 9.2 psi (0,63 bar)	20 GPM (75,7 LPM) 12.8 psi (0,88 bar)	20 GPM (75,7 LPM) 12.8 psi (0,88 bar)
14 x 14 (4,3 x 4,3)	14 (4,3)	19 GPM (71,9 LPM) 11.5 psi (0,79 bar)	19 GPM (71,9 LPM) 11.5 psi (0,79 bar)	22 GPM (83,3 LPM) 15.4 psi (1,06 bar)	22 GPM (83,3 LPM) 15.4 psi (1,06 bar)
16 x 14 (4,9 x 4,3)	16 (4,9)	20 GPM (75,7 LPM) 12.8 psi (0,88 bar)	20 GPM (75,7 LPM) 12.8 psi (0,88 bar)	24 GPM (90,8 LPM) 18.4 psi (1,27 bar)	24 GPM (90,8 LPM) 18.4 psi (1,27 bar)
16 x 16 (4,9 x 4,9)	16 (4,9)	24 GPM (90,8 LPM) 18.4 psi (1,27 bar)	24 GPM (90,8 LPM) 18.4 psi (1,27 bar)	28 GPM (106,0 LPM) 25.0 psi (1,72 bar)	28 GPM (106,0 LPM) 25.0 psi (1,72 bar)
16 x 18 (4,9 x 5,5)	16 (4,9)	26 GPM (98,4 LPM) 21.6 psi (1,49 bar)	26 GPM (98,4 LPM) 21.6 psi (1,49 bar)	31 GPM (117,3 LPM) 30.6 psi (2,11 bar)	31 GPM (117,3 LPM) 30.6 psi (2,11 bar)
16 x 20 (4,9 x 6,1)	16 (4,9)	29 GPM (109,8 LPM) 26.8 psi (1,85 bar)	29 GPM (109,8 LPM) 26.8 psi (1,85 bar)	37 GPM (140,0 LPM) 43.7 psi (3,01 bar)	37 GPM (140,0 LPM) 43.7 psi (3,01 bar)

- (a) For coverage area dimensions less than or between those indicated, it is necessary to use the minimum required flow for the next highest coverage area for which hydraulic design criteria are stated.
- (b) Width (backwall where sprinkler is located) x Length (horizontal throw of sprinkler).
- (c) Requirement is based on minimum flow in GPM (LPM) from each sprinkler. The associated residual pressures are calculated using the nominal K-factor. Refer to Hydraulic Design Criteria Section for details.
- (d) Sidewall sprinklers, where installed under a ceiling with a slope greater than 0 inch rise for a 12 inch run to a slope up to 2 inch rise for 12 inch run, must be located per one of the following:
 - Locate the sprinklers at the high point of the slope and positioned to discharge down the slope.
 - Locate the sprinklers along the slope and positioned to discharge across the slope.

TABLE A
NFPA 13D AND NFPA 13R WET PIPE HYDRAULIC DESIGN CRITERIA
FOR THE SERIES LFII (TY3334)
RESIDENTIAL HORIZONTAL SIDEWALL AND RECESSED HORIZONTAL SIDEWALL SPRINKLERS
FOR HORIZONTAL CEILING (Maximum 2 Inch Rise for 12 Inch Run)

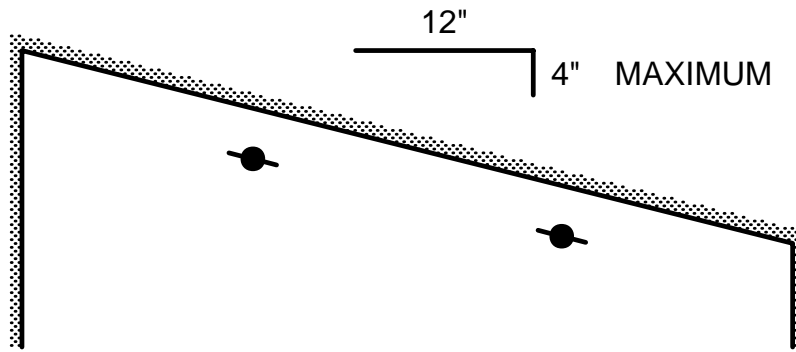

ELEVATION

Maximum Coverage Area ^(a) Width x Length ^(b) Ft. x Ft. (m x m)	Maximum Spacing Ft. (m)	Minimum Flow ^(c) and Residual Pressure Two sprinkler design with the sprinklers located along the slope and positioned to discharge across the slope.			
		Top-Of-Deflector- To- Ceiling: 4 to 6 Inches (100 to 150 mm)		Top-Of-Deflector- To- Ceiling: 6 to 12 Inches (150 to 300 mm)	
		155°F/68°C	175°F/79°C	155°F/68°C	175°F/79°C
16 x 16 (4,9 x 4,9)	16 (4,9)	24 GPM (90,8 LPM) 18.4 psi (1,27 bar)	24 GPM (90,8 LPM) 18.4 psi (1,27 bar)	24 GPM (90,8 LPM) 18.4 psi (1,27 bar)	24 GPM (90,8 LPM) 18.4 psi (1,27 bar)

- (a) For coverage area dimensions less than or between those indicated, it is necessary to use the minimum required flow for the next highest coverage area for which hydraulic design criteria are stated.
- (b) Width (backwall where sprinkler is located) x Length (horizontal throw of sprinkler).
- (c) Requirement is based on minimum flow in GPM (LPM) from each sprinkler. The associated residual pressures are calculated using the nominal K-factor. Refer to Hydraulic Design Criteria Section for details..

TABLE B
NFPA 13D AND NFPA 13R WET PIPE HYDRAULIC DESIGN CRITERIA
FOR THE SERIES LFII (TY3334)
RESIDENTIAL HORIZONTAL SIDEWALL AND RECESSED HORIZONTAL SIDEWALL SPRINKLERS
FOR SPRINKLERS LOCATED ALONG A SLOPE AND DISCHARGING ACROSS THE SLOPE
(Greater Than 2 Inch Rise for 12 Inch Run Up To 4 Inch Rise for 12 Inch Run)

by wiping the sprinkler with a cloth or by brushing it with a soft bristle brush.

Care must be exercised to avoid damage to the sprinklers - before, during, and after installation. Sprinklers damaged by dropping, striking, wrench twist/slippage, or the like, must be replaced. Also, replace any sprinkler that has a cracked bulb or that has lost liquid from its bulb. (Ref. Installation Section).

The owner is responsible for the inspection, testing, and maintenance of their fire protection system and devices in compliance with this document, as well as with the applicable standards of the National Fire Protection Association (e.g., NFPA 25), in addition to the standards of any other authorities having jurisdiction. The installing contractor or sprinkler manufacturer should be contacted relative to any questions.

NOTE

The owner must assure that the sprinklers are not used for hanging of any objects and that the sprinklers are only cleaned by means of gently dusting with a feather duster; otherwise, non-operation in the event of a fire or inadvertent operation may result.

It is recommended that automatic sprinkler systems be inspected, tested, and maintained by a qualified Inspection Service in accordance with local requirements and/or national code.

Limited Warranty

Products manufactured by Tyco Fire & Building Products (TFBP) are warranted solely to the original Buyer for ten (10) years against defects in material and workmanship when paid for and properly installed and maintained under normal use and service. This warranty will expire ten (10) years from date of shipment by TFBP. No warranty is given for products or components manufactured by companies not affiliated by ownership with TFBP or for products and components which have been subject to misuse, improper installation, corrosion, or which have not been installed, maintained, modified or repaired in accordance with applicable Standards of the National Fire Protection Association, and/or the standards of any other Authorities Having Jurisdiction. Materials found by TFBP to be defective shall be either repaired or replaced, at TFBP's sole option. TFBP neither assumes, nor authorizes any person to assume for it, any other obligation in connection with the sale of products or parts of products. TFBP shall not be responsible for sprinkler system design errors or inaccurate or incomplete information supplied by Buyer or Buyer's representatives.

In no event shall TFBP be liable, in contract, tort, strict liability or under any other legal theory, for incidental, indirect, special or consequential damages, including but not limited to labor charges, regardless of whether TFBP was informed about the possibility of such damages, and in no event shall TFBP's liability exceed an amount equal to the sales price.

The foregoing warranty is made in lieu of any and all other warranties, express or implied, including warranties of merchantability and fitness for a particular purpose.

This limited warranty sets forth the exclusive remedy for claims based on failure of or defect in products, materials or components, whether the claim is made in contract, tort, strict liability or any other legal theory.

This warranty will apply to the full extent permitted by law. The invalidity, in whole or part, of any portion of this warranty will not affect the remainder.

Ordering Procedure

When placing an order, indicate the full product name. Contact your local distributor for availability..

Sprinkler Assembly:

Series LFII (TY3334), K=5.6, Residential Horizontal Sidewall Sprinkler with (specify) temperature rating and (specify) finish, P/N (specify).

155°F/68°C

Chrome Plated	P/N 51-524-9-155
White Coated	P/N 51-524-4-155
White (RAL9010)*	P/N 51-524-3-155
Natural Brass	P/N 51-524-1-155

175°F/79°C

Chrome Plated	P/N 51-524-9-175
White Coated	P/N 51-524-4-175
White (RAL9010)*	P/N 51-524-3-175
Natural Brass	P/N 51-524-1-175

* Eastern Hemisphere sales only.

Recessed Escutcheon:

Specify: Style 20 Recessed Escutcheon with (specify*) finish, P/N (specify*).

* Refer to Technical Data Sheet TFP770.

Sprinkler Wrench:

Specify: W-Type 6 Sprinkler Wrench, P/N 56-000-6-387.

Specify: W-Type 7 Sprinkler Wrench, P/N 56-850-4-001.