

## ***INSTALLATION INSTRUCTIONS***

1. Locate and cut a hole in the wall to accommodate a 3/4" pipe through which the impeller-driven shaft will pass.
2. Cut 3/4" pipe (item 1) to 2" longer than wall thickness. Thread with 3/4" NPT.
3. Cut drive shaft (item 2) to 2" longer than pipe length.
4. Attach 3/4" pipe (item 1) to gong bracket (item 3) without detaching gong. Position this assembly on outside wall, sliding 3/4" pipe through pre-drilled hole. (Note: In some cases, the gong must be removed and holes in the gong bracket (item 3) must be used to secure gong bracket to wall to prevent unwanted rotation.) On the inside wall, slide 4" x 4" wall plate (item 8) over protruding 3/4" pipe and secure with 3/4" jam nut. Pipe and gong assembly are now attached securely through wall.
5. From impeller housing (item 5) remove six cover screws, cover (item 4), cover gasket (item 9) and impeller (item 6).
6. Attach impeller housing to 3/4" pipe (item 1) and tighten.
7. Insert drive shaft (item 2) through 3/4" pipe so that it engages with striker shaft (item 7).
8. Place impeller in housing and rotate to engage with drive shaft. Once engaged, turn several times to assure assembly is free to move.
9. Replace cover gasket and plate, then secure with six screws.
10. Attach piping from alarm valve or retard chamber, dry pipe, deluge or preaction valve to impeller housing fitting. Run drain to safe location.
11. Test alarm for proper operation.

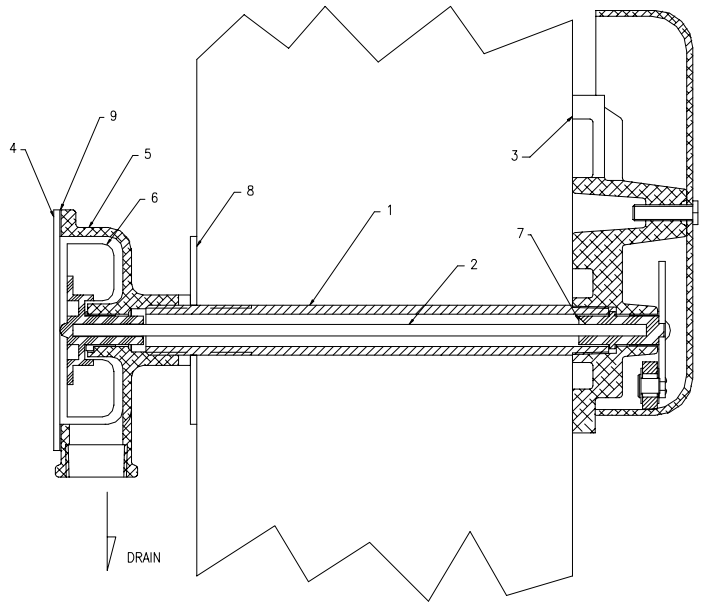

## ***MAINTENANCE***

1. The 3/4" strainer located between the alarm, dry pipe, deluge or preaction valve and impeller housing should be cleaned periodically to assure sufficient water flow to sound alarm.
2. The cleanout plug on the impeller housing should be periodically removed and the housing cleaned to avoid debris and accumulation that could hinder alarm operation.
3. The inside of the gong should be checked periodically for accumulation of foreign matter and cleaned accordingly.

## ***INSTALLATION INSTRUCTIONS***

1. Locate and cut a hole in the wall to accommodate a 3/4" pipe through which the impeller-driven shaft will pass.
2. Cut 3/4" pipe (item 1) to 2" longer than wall thickness. Thread with 3/4" NPT.
3. Cut drive shaft (item 2) to 2" longer than pipe length.
4. Attach 3/4" pipe (item 1) to gong bracket (item 3) without detaching gong. Position this assembly on outside wall, sliding 3/4" pipe through pre-drilled hole. (Note: In some cases, the gong must be removed and holes in the gong bracket (item 3) must be used to secure gong bracket to wall to prevent unwanted rotation.) On the inside wall, slide 4" x 4" wall plate (item 8) over protruding 3/4" pipe and secure with 3/4" jam nut. Pipe and gong assembly are now attached securely through wall.
5. Remove gong shell (item 10) from impeller housing (item 5). Remove striker assembly (item 12) and nylon bearing (item 13). From impeller housing, remove six backing plate screws, backing plate (item 4), backing plate gasket (item 9) and impeller (item 6).
6. Attach impeller housing to 3/4" pipe (item 1) and tighten.
7. Insert drive shaft (item 2) through 3/4" pipe so that it engages with striker shaft (item 7).
8. Place impeller in housing and rotate to engage with drive shaft. Once engaged, turn several times to assure assembly is free to move.
9. Replace backing plate gasket (item 9) and plate (item 4), then secure with six screws.
10. Place nylon bearing (item 13) over inside gong impeller shaft (item 6). Mount striker arm assembly (item 12) to shaft with screw (item 14). Rotate to assure freedom of movement. Mount inside gong shell.
10. Attach piping from alarm valve or retard chamber, dry pipe, deluge or preaction valve to impeller housing fitting. Run drain to safe location.
11. Test alarm for proper operation.

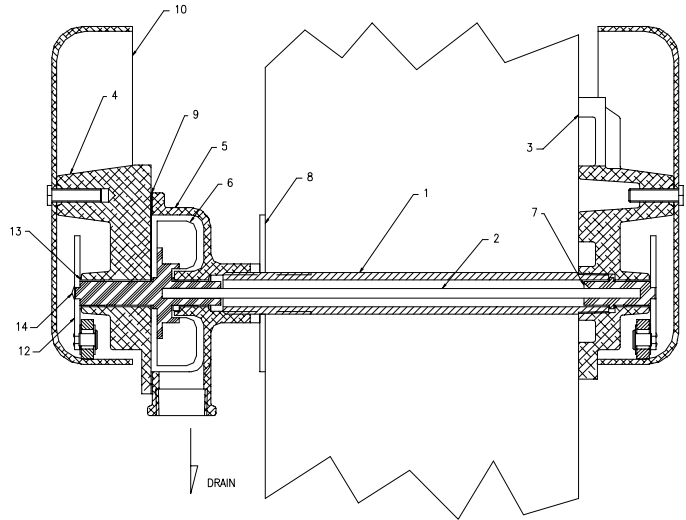

## ***MAINTENANCE***

1. The 3/4" strainer located between the alarm, dry pipe, deluge or preaction valve and impeller housing should be cleaned periodically to assure sufficient water flow to sound alarm.
2. The cleanout plug on the impeller housing should be periodically removed and the housing cleaned to avoid debris and accumulation that could hinder alarm operation.
3. The inside of the gong should be checked periodically for accumulation of foreign matter and cleaned accordingly.