

**VANE TYPE WATERFLOW ALARM SWITCH  
WITH RETARD AND GLUE-IN UNION**



**Stock No. 1113555**  
**1113600 W/TSK**

**Service Use:**

Automatic Sprinkler  
One or two family dwelling  
Residential occupancy up to four stories  
National Fire Alarm Code

NFPA-13  
NFPA-13D  
NFPA-13R  
NFPA-72

- CUL, UL and CSFM Listed, CE Marked, NYMEA ACCEPTED**
- Service Pressure:** Up to 175 PSI (12,07 BAR)
- Minimum Flow Rate for Alarm:** 8-10 GPM (30-38 LPM)
- Maximum Surge:** 18 FPS (5,5 m/s)
- Enclosure:** Die-cast, red powdercoat finish
- No. 1113555:** Cover held in place with tamper resistant screws
- No. 1113600 - Tamper:** Cover incorporates micro-switch.
  - Cover Tamper:** Activated by cover removal.
  - Cover Tamper Switch Contacts:** One set SPDT, Rated at 250VAC.
  - Cover Tamper Switch Terminations:** 8" 22AWG wire leads.
- Contact Ratings:** Two sets of SPDT (Form C)
  - 15.0 Amps at 125/250 VAC
  - 2.0 Amps at 30 VDC
- Conduit Entrances:** Two knockouts provided for 1/2" conduit.
- Usage:** Listed CPVC plastic piping systems manufactured by Central Sprinkler Corp., Grinnell Sprinkler Corp., Spears Manufacturing Co., and IPEX (Scepter). Fits pipe sizes - 1", 1-1/4", 1-1/2" and 2"
- Environmental Specifications:**
  - Suitable for indoor or outdoor use with factory installed gasket and die-cast housing.
  - For NEMA 4/IP55 rated enclosure - use with appropriate conduit fitting and/or plugs.
  - Temperature range: 40° F to 120° F (4,5° C to 49° C)
- Caution:** This device is not intended for applications in explosive environments.

The Model VSR-SFG is a vane type waterflow switch for use on wet sprinkler systems using CPVC plastic fittings manufactured by Central Sprinkler Corp., Grinnell Sprinkler Corp., Spears Manufacturing Co., and IPEX (Scepter) that use 1", 1-1/4", 1-1/2" or 2" pipe sizes. It is equipped with a union to accommodate installation in confined spaces.

The unit contains two single pole double throw snap action switches and an adjustable, instantly recycling pneumatic retard. The switches are actuated when a flow of 8-10 gallons per minute (30-38 liters per minute) or more occurs downstream of the device. The flow condition must exist for a period of time necessary to overcome the selected retard period.

**INSTALLATION:** These devices may be mounted on horizontal or vertical pipe. On horizontal pipe they should be installed on the top side of the pipe where they will be accessible. The units should not be installed within 6" (15 cm) of a valve, drain or fitting which changes the direction of the waterflow. The unit has a 1" male fitting for gluing into a CPVC plastic TEE.

Loosen the union nut and separate the 1" male fitting from the VSR-SFG. Glue the 1" male fitting into the TEE following the TEE manufacturer's instructions for preparation and gluing of CPVC piping systems. (NOTE:

The 1" male fitting must bottom out on the stop of the TEE for proper operation of the VSR-SFG. See Fig. 1.) Wait 2 to 4 hours to allow the glue to dry before attaching the VSR-SFG to the 1" male fitting. Select the proper paddle for the pipe size and type of TEE used. See Fig. 3 and Fig. 5 for instructions on how to change paddle. Verify that the o-ring is properly positioned in its groove. Hand tighten the nut on the union after orienting the device in the appropriate direction to detect waterflow as shown in Fig. 2.

**CAUTION: Do not over-tighten the union nut, hand tighten only!**  
The vane must not rub the inside of the TEE or bind in any way. The stem should move freely when operated by hand.

**INSPECTION AND TESTING:** Check the operation of the unit by opening the inspector's test valve at the end of the sprinkler line or the drain and test connection, if an inspector's test valve is not provided.

If there are no provisions for testing the operation of the flow detection device on the system, application of the VSR-SFG is not recommended or advisable.

The frequency of the inspection and testing and its associated protective monitoring system should be in accordance with the applicable NFPA Codes and Standards and/or authority having jurisdiction (manufacturer recommends quarterly or more frequently).

### VANE TYPE WATERFLOW ALARM SWITCH WITH RETARD AND GLUE-IN UNION

FIG. 1

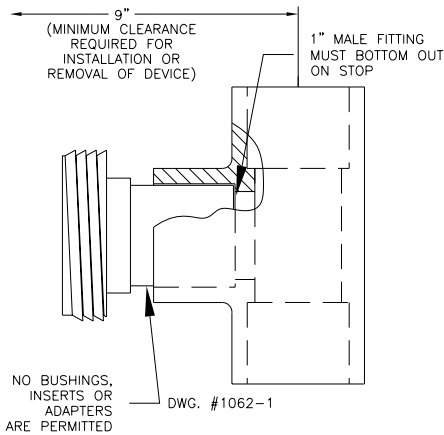

Glue the 1" male fitting into the TEE following the TEE manufacturer's instructions for preparation and gluing of CPVC piping systems. Wait 2 to 4 hours to allow the glue to dry before attaching the VSR-SFG to the 1" male fitting.

FIG. 2

**Retard Adjustment:**

To change time, turn knob (either direction) for desired time delay. Use the minimum amount of retard necessary to prevent false alarms. A "B" setting is usually adequate for this. Factory set at "B".

APPROX. RETARD SETTINGS (IN SEC.)					
0	A	B	C	D	E
0	10-25	20-40	35-55	50-70	60-90

DO NOT LEAVE COVER OFF FOR EXTENDED PERIOD OF TIME

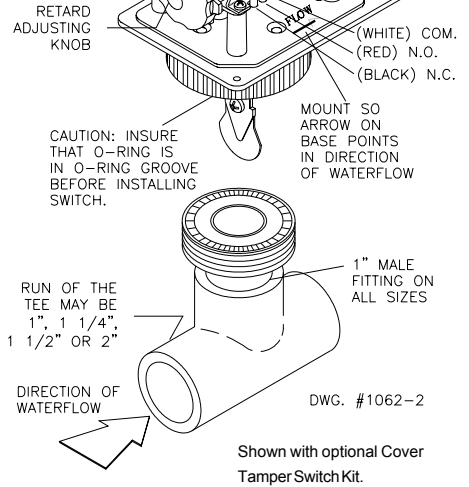
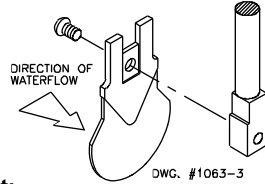

FIG. 3



**Important:**

7 paddles are furnished with each unit to accommodate the various sizes and manufacturers of TEES. The paddles have raised lettering that show the pipe size and the TEE manufacturer they are to be used with. The proper paddle must be used. The paddle must be properly attached (see Fig. 3) and the screw that holds the paddle must be securely tightened.

FIG. 4 TYPICAL ELECTRICAL CONNECTIONS

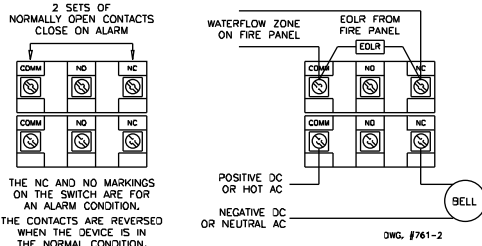

**NOTES:**

1. The model VSR-SFG has two switches, one can be used to operate a central station, proprietary or remote signaling unit, while the other is used to operate a local audible or visual annunciator.
2. For supervised circuits see "Switch Terminal Connections" drawing and caution note (Fig. 6).

**COVER TAMPER SWITCH**

(SHOWN WITH COVER IN PLACE)

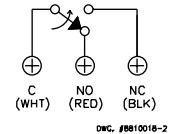
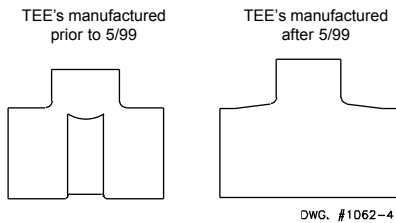

FIG. 5 GRINNELL TEE



**NOTICE:**

As of 5/99 Grinnell has changed the design of their TEE fittings. The new fittings will require the use of the standard paddle, while you will still be required to use the paddle marked Grinnell on all fittings manufactured prior to this date. Failure to install the correct paddle could cause the device to malfunction or operate improperly.

FIG. 6 SWITCH TERMINAL CONNECTIONS CLAMPING PLATE TERMINAL

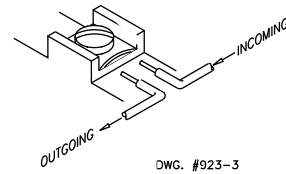

**CAUTION:**

An uninsulated section of a single conductor should not be looped around the terminal and serve as two separate connections. The wire must be severed, thereby providing supervision of the connection in the event that the wire becomes dislodged from under the terminal.

**APPLICATION WARNING!**

Due to the possibility of unintended discharges caused by pressure surges, trapped air, or short retard times, waterflow switches that are monitoring wet pipe sprinkler systems should not be used as the sole initiating device to discharge AFFF, deluge, or chemical suppression systems.