



Stock No. 1113777
1113605 W/TSK

Service Use:

Automatic Sprinkler	NFPA-13
One or two family dwelling	NFPA-13D
Residential occupancy up to four stories	NFPA-13R
National Fire Alarm Code	NFPA-72

The Model VSR-SFT is a vane type waterflow switch for use on wet sprinkler systems that use 1", 1-1/4", 1-1/2" or 2" pipe sizes. It is equipped with a union to accommodate installation in confined spaces.

The unit contains two single pole double throw snap action switches and an adjustable, instantly recycling pneumatic retard. The switches are actuated when a flow of 8-10 gallons per minute (30-38 liters per minute) or more occurs downstream of the device. The flow condition must exist for a period of time necessary to overcome the selected retard period.

INSTALLATION: These devices may be mounted in horizontal or vertical pipe. On horizontal pipe they should be installed on the top side of the pipe where they will be accessible. The units should not be installed within 6" (15 cm) of a valve, drain or fitting which changes the direction of the waterflow. The unit has a 1" NPT fitting for threading into a non-corrosive TEE. See Fig. 1 for proper TEE size, type and installation. Select the proper paddle for the pipe size and type of TEE used. See Fig. 3 for instructions on how to change the paddle.

Loosen the union nut and separate the 1" NPT fitting from the VSR-SFT. Use no more than three wraps of teflon tape as thread lubricant. Reattach the VSR-SFT to the 1" NPT fitting, verifying that

CUL, UL and CSFM Listed, CE Marked, NYMEA ACCEPTED

Service Pressure: Up to 175 PSI (12,07 BAR)

Minimum Flow Rate for Alarm: 8-10 GPM (30-38 LPM)

Maximum Surge: 18 FPS (5,5 m/s)

Enclosure: Die-cast, red powdercoat finish

No. 1113777: Cover held in place with tamper resistant screws

No. 1113605 - Tamper: Cover incorporates micro-switch.

Cover Tamper: Activated by cover removal.

Cover Tamper Switch Contacts: One set SPDT, Rated at 250VAC.

Cover Tamper Switch Terminations: 8" 22AWG wire leads.

Contact Ratings: Two sets of SPDT (Form C)
15.0 Amps at 125/250 VAC
2.0 Amps at 30 VDC

Conduit Entrances: Two knockouts provided for 1/2" conduit.

Usage: Listed plastic, copper and schedule 40 iron pipe.
Fits pipe sizes - 1", 1-1/4", 1-1/2" and 2"
Note: 12 paddles are furnished with each unit, one for each pipe size of threaded and sweat TEE, one for 1" CPVC, one for 1" CPVC (Central), one for 1-1/2" polybutylene and one for 1-1/2" threaded (Japan).

Environmental Specifications:

- Suitable for indoor or outdoor use with factory installed gasket and die-cast housing.
- For NEMA 4/IP55 rated enclosure - use with appropriate conduit fitting and/or plugs.
- Temperature range: 40° F to 120° F (4,5° C to 49° C)

Caution: This device is not intended for applications in explosive environments.

the o-ring is properly positioned in its groove. Hand tighten the nut on the union after orienting the device in the appropriate direction to detect waterflow as shown in Fig. 2.

CAUTION: Do not over-tighten the union nut, hand tighten only!

The vane must not rub the inside of the TEE or bind in any way. The stem should move freely when operated by hand.

The device can also be used in copper or plastic pipe installations with the proper adapters so that the specified TEE fitting may be installed on the pipe run.

INSPECTION AND TESTING: Check the operation of the unit by opening the inspector's test valve at the end of the sprinkler line or the drain and test connection, if an inspector's test valve is not provided.

If there are no provisions for testing the operation of the flow detection device on the system, application of the VSR-SFT is not recommended or advisable.

The frequency of the inspection and testing and its associated protective monitoring system should be in accordance with the applicable NFPA Codes and Standards and/or authority having jurisdiction (manufacturer recommends quarterly or more frequently).

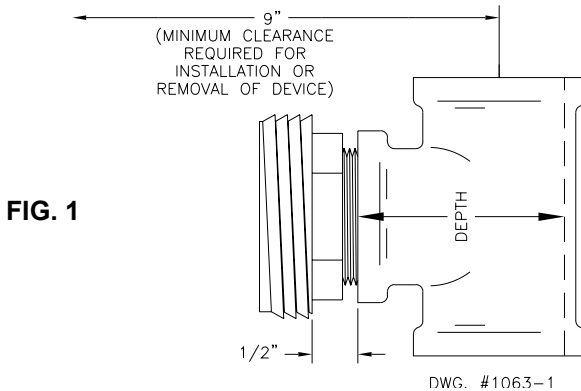

FIG. 1

Screw the fitting into the TEE fitting as shown. On sweat TEE's, no threaded bushings, inserts or adapters are permitted unless they comply with the dimensions listed in the chart below.

Caution: To prevent leakage apply teflon tape sealant to the 1" NPT male fitting only. Do not use any other type of lubricant or sealant.

Important - the depth to the inside bottom of the TEE should have the following dimensions:

APPROXIMATE DEPTH REQUIREMENT				
TEE SIZE	THREADED	SWEAT	POLYBUTYLENE	CPVC
1" x 1" x 1"	2-1/16"	1-3/4"	N/A	2-7/16"
1-1/4" x 1-1/4" x 1"	2-7/16"	2-7/16"	N/A	N/A
1-1/2" x 1-1/2" x 1"	2-11/16"	2-1/4"	2-1/2"	N/A
2" x 2" x 1"	3-3/16"	2-3/4"	N/A	N/A

FIG. 2

Retard Adjustment:

To change time, turn knob (either direction) for desired time delay. Use the minimum amount of retard necessary to prevent false alarms. A "B" setting is usually adequate for this. Factory set at "B".

APPROX. RETARD SETTINGS (IN SEC.)					
0	A	B	C	D	E
0	10-25	20-40	35-55	50-70	60-90

FIG. 3

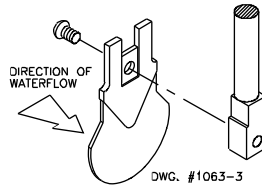

Important:

There are 12 paddles furnished with each unit. One for each size of threaded, sweat or plastic TEE as described in Fig. 1. **The paddles have raised lettering that show the pipe size and type of TEE that they are to be used with. The proper paddle must be used.** The paddle must be properly attached (see Fig. 3) and the screw that holds the paddle must be securely tightened.

DO NOT LEAVE COVER OFF FOR EXTENDED PERIOD OF TIME

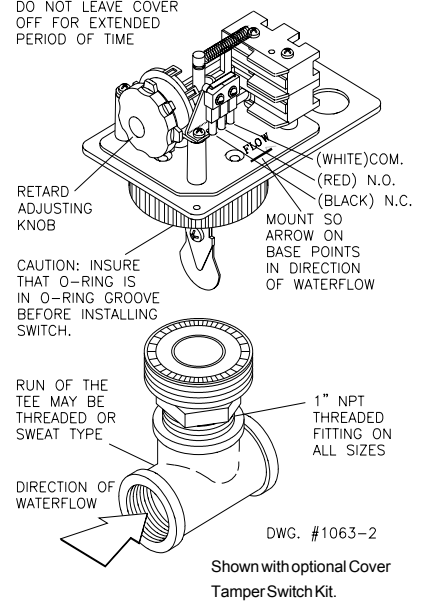

SWITCH TERMINAL CONNECTIONS CLAMPING PLATE TERMINAL

FIG. 4

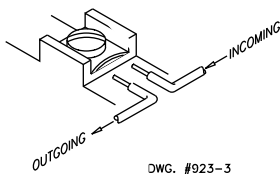

CAUTION:

An uninsulated section of a single conductor should not be looped around the terminal and serve as two separate connections. The wire must be severed, thereby providing supervision of the connection in the event that the wire becomes dislodged from under the terminal.

COVER TAMPER SWITCH (SHOWN WITH COVER IN PLACE)

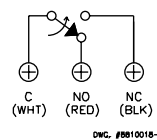
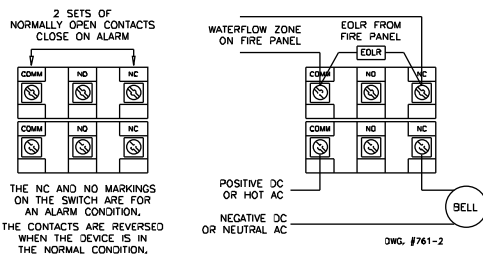

FIG. 5

TYPICAL ELECTRICAL CONNECTIONS



NOTES:

1. The model VSR-SFT has two switches, one can be used to operate a central station, proprietary or remote signaling unit, while the other is used to operate a local audible or visual annunciator.
2. For supervised circuits see "Switch Terminal Connections" drawing and caution note (Fig. 4).

APPLICATION WARNING!

Due to the possibility of unintended discharges caused by pressure surges, trapped air, or short retard times, waterflow switches that are monitoring wet pipe sprinkler systems should not be used as the sole initiating device to discharge AFFF, deluge, or chemical suppression systems.